

Stauffer Diesel / Stadco Ultra-Compact Power Packs

DEUTZ TD2.9 DIESEL ♦ EPA T4 Final

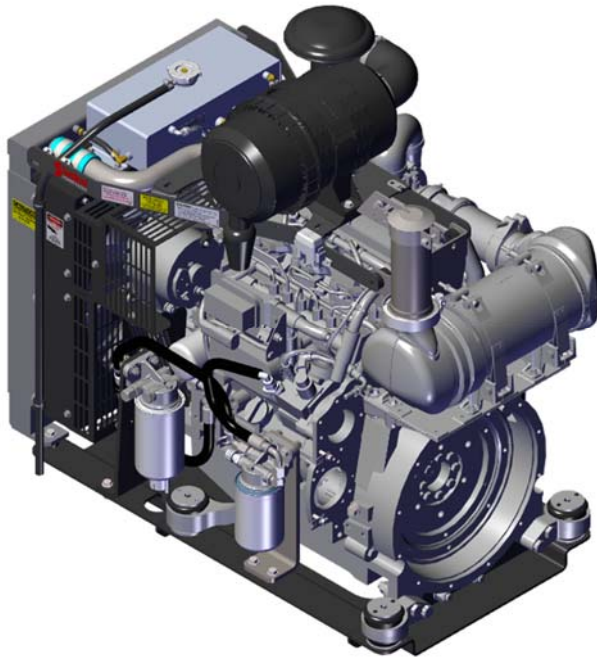

DEUTZ TD2.9 - 74 hp DIESEL - Open Power Pack

- ◆ Each compact power unit is fully assembled and test run at Stauffer Diesel / Stadco.
- ◆ Compact power units are engineered and EPA Tier 4 Final certified as a unit.
- ◆ Engineering pre-validated. Minimal application installation approval is required.
- ◆ Routine service points are all on one side.
- ◆ DEUTZ 4-cylinder, water-cooled model:
TD 2.9 turbo-charged 74 hp @ 2600 RPM.
- ◆ DEUTZ TD 2.9 with "DOC only" exhaust after treatment equals maintenance free operation under all applications and ambient conditions. DOC is open type, flow-through design, requires no down-time and no regeneration.
- ◆ Murphy TEC-10® control panels are standard on all compact power units. TEC-10® is flexible and rugged, withstands harsh weather environments, and offers easy to read displays even in sunlight.
- ◆ Control panel - furnished with a pre-wired harness for remote mounting.

Stauffer Diesel Inc / Stadco



DEUTZ Distributor since 1956

34 Stauffer Lane Ephrata, PA 17522 ♦ mail@staufferdiesel.com ♦ 717-738-2500 ♦ www.staufferdiesel.com

S211.23 Rev 00

TD2.9 SDI Open Power Pack

Engine Type	TD 2.9	
No. of cylinders	4	
Bore/stroke	mm in	92/110 3.6/4.3
Displacement	L cu in	2.9 177
Max. nominal speed	min -1 rpm	2600
Power output as per ISO 14396 *	kW hp	55.4 74
at speed	min -1 rpm	2600
Max. torque	Nm lb/ft	260 192
at speed	min -1 rpm	1600 - 1800
Minimum idling speed	min -1 rpm	900
Specific fuel consumption **	g/kWh lb/hph	225 0.37
Power Unit weight with fluids	lbs	945

*Power data without deduction of fan power

**Best point consumption refers to diesel with a density of 0.835 kg/dm³ at 15°C.

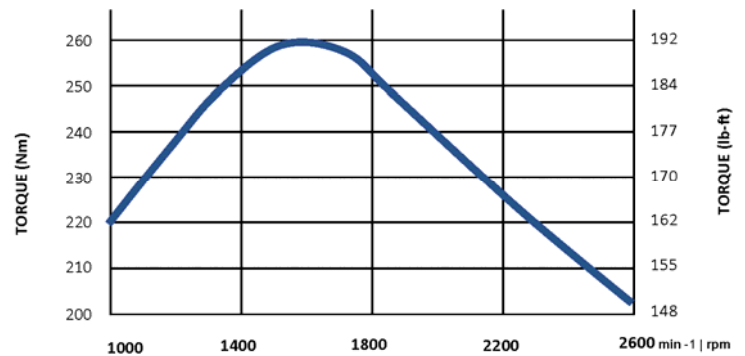
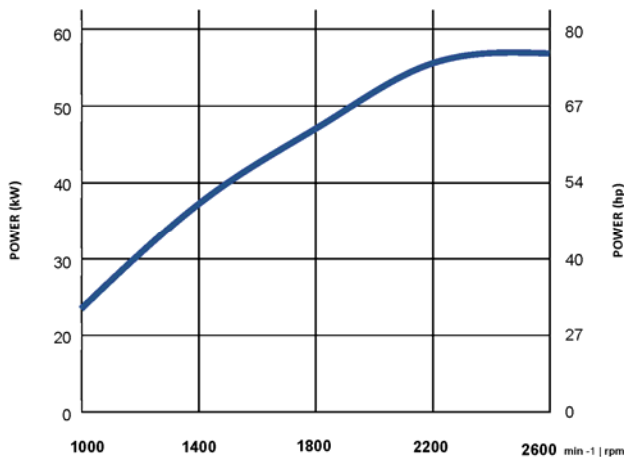
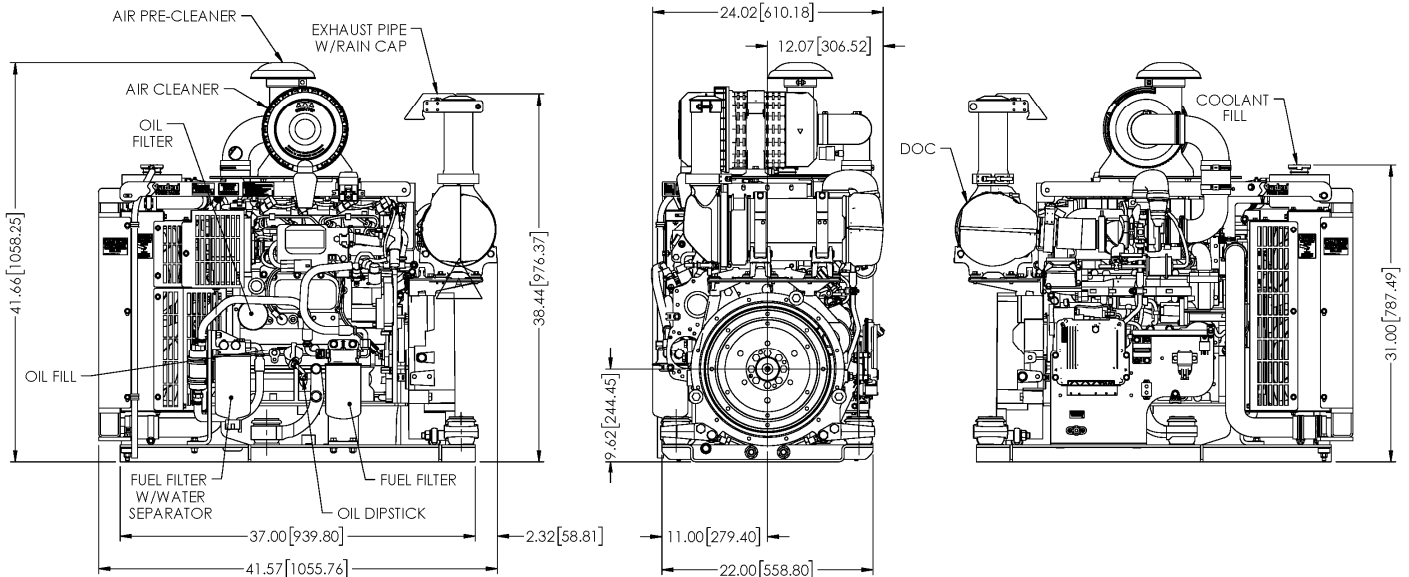

Stauffer Diesel Inc / Stadco



DEUTZ Distributor since 1956

34 Stauffer Lane Ephrata, PA 17522 ♦ mail@staufferdiesel.com ♦ 717-738-2500 ♦ www.staufferdiesel.com

S211.23 Rev 00

TD2.9 SDI Enclosed Power Pack

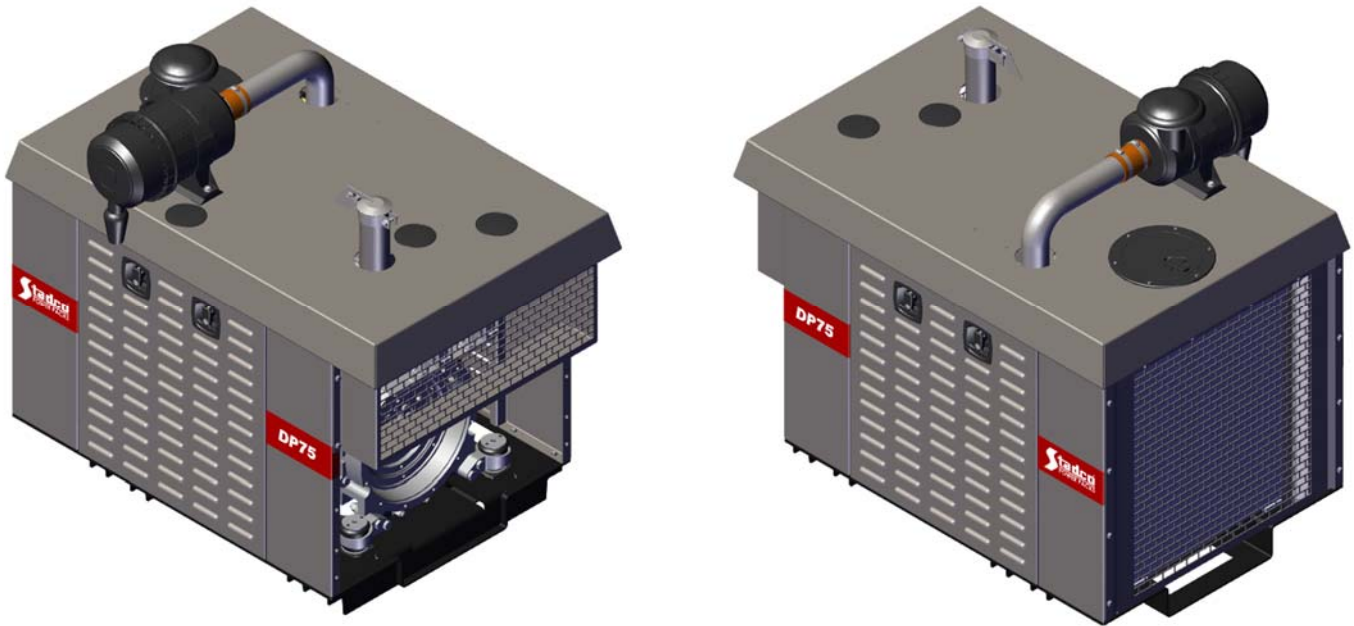

DEUTZ TD2.9 - 74 hp DIESEL - Enclosed Power Pack

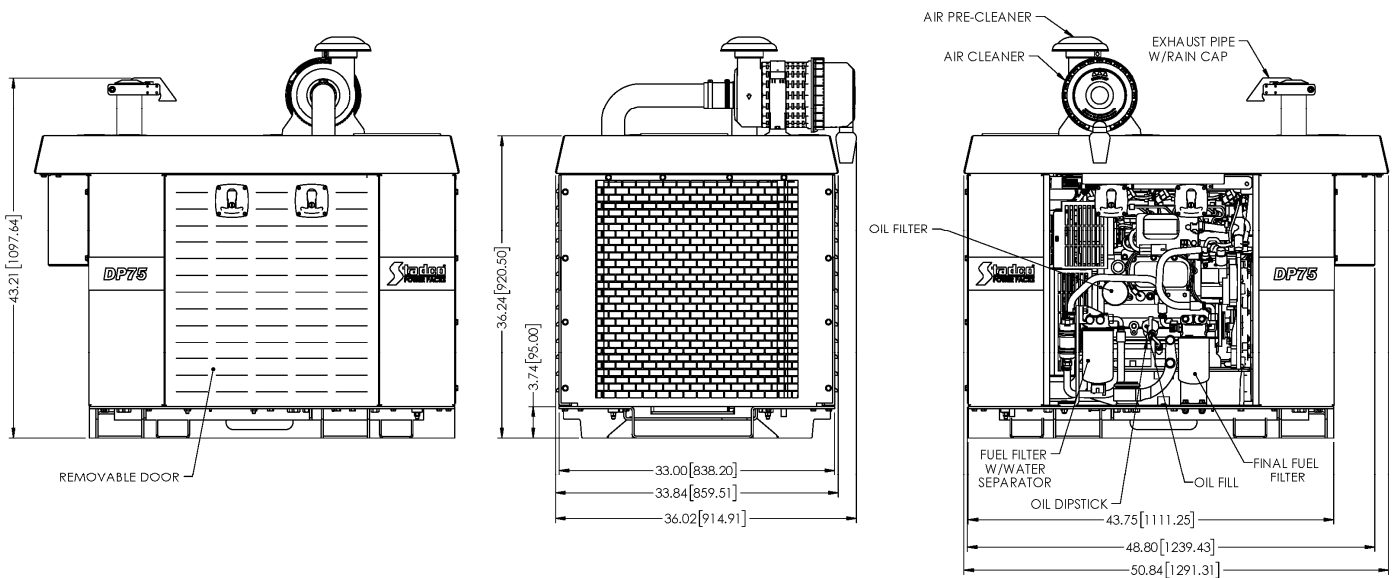

Stauffer Diesel Inc / Stadco



DEUTZ Distributor since 1956

34 Stauffer Lane Ephrata, PA 17522 ♦ mail@staufferdiesel.com ♦ 717-738-2500 ♦ www.staufferdiesel.com

S211.23 Rev 00