

Stauffer Diesel / Stadco **FPT Power Packs**

POWERTRAIN TECHNOLOGIES

FPT F34 Series - 74 hp Industrial Diesel ♦ EPA T4F

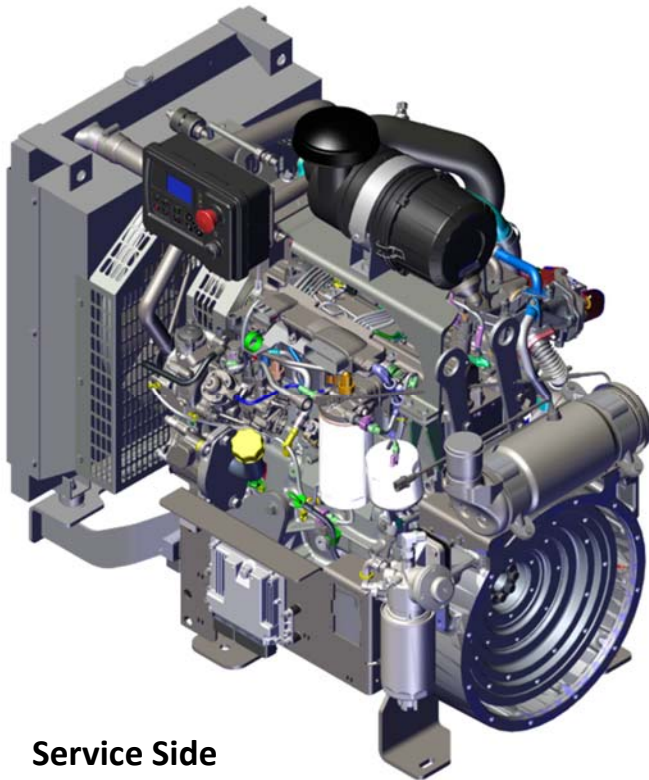

Service Side

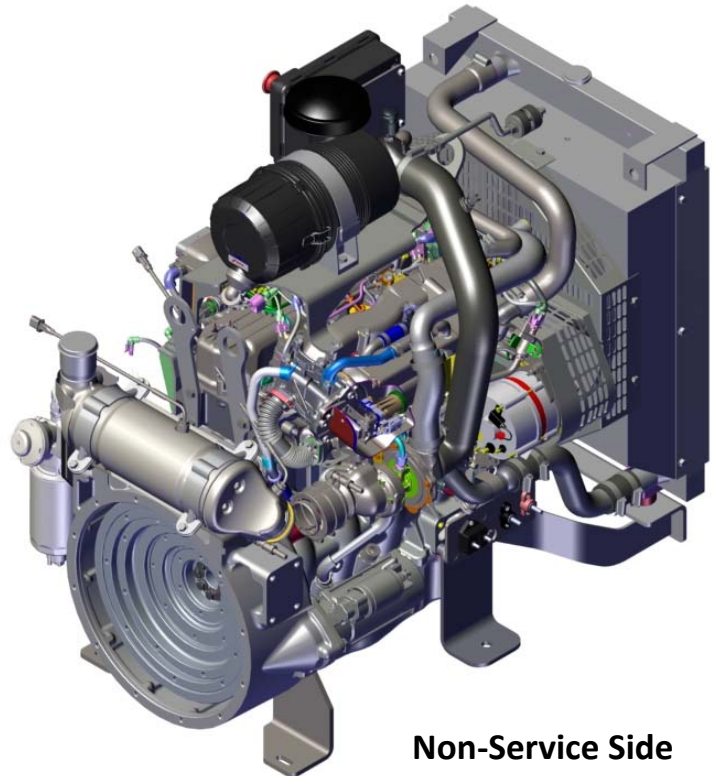

Non-Service Side

FPT F34 - 74 hp Diesel—Pedestal Version

- ◆ Each compact power unit is fully assembled and test run at Stauffer Diesel / Stadco.
- ◆ Power units are pre-engineered as a compact “Turn-Key” unit and emissions compliance is pre-validated.
- ◆ Minimal application installation approval is required.
- ◆ All accessories offered with this build are mounted and certified.
- ◆ FPT F34 74 hp is turbo-charged with “DOC/PM” DOC only catalyst exhaust after treatment system is regeneration-free. System is open type, flow-through design, requires no down-time. EGR-free combustion.
- ◆ Murphy TEC-10® control panels are standard on all compact power units. TEC-10® is flexible and rugged, withstands harsh weather environments, and offers easy to read displays even in sunlight.

Stauffer Diesel Inc / Stadco  **Industrial Engine Distributor since 1956**

FPT F34 Diesel - 74hp Industrial

Engine Type

No. of cylinders		4
Bore/Stroke	mm in	90 x 110 3.9 x 4.3
Displacement	L Cu in	3.4 207
Max. nominal speed	Min -1 Rpm	2200
Power output *	kW hp	55 74
Max. torque	Nm Lb/ft	315 232
At Speed	Min -1 rpm	1400
Specific Fuel consumption** (Common Rail)	g/kWh Lb/hph	215 0.355
Dry weight (Base Engine Only)	Kg. Lbs.	390 860
ATS Tier 4 Final		EGR + DOC

*Power data without deduction of fan power

**Best point consumption refers to diesel with a density of 0.835 kg/dm³ at 15°C.

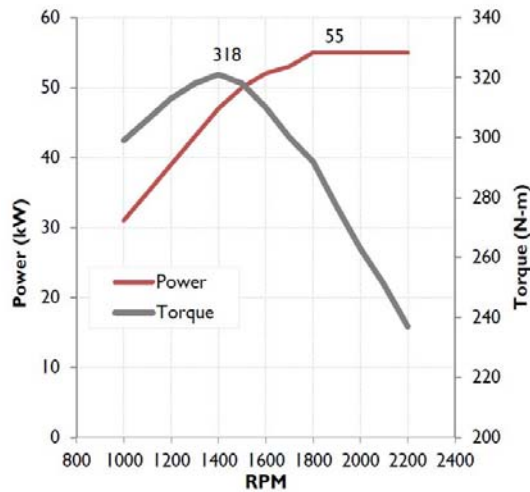
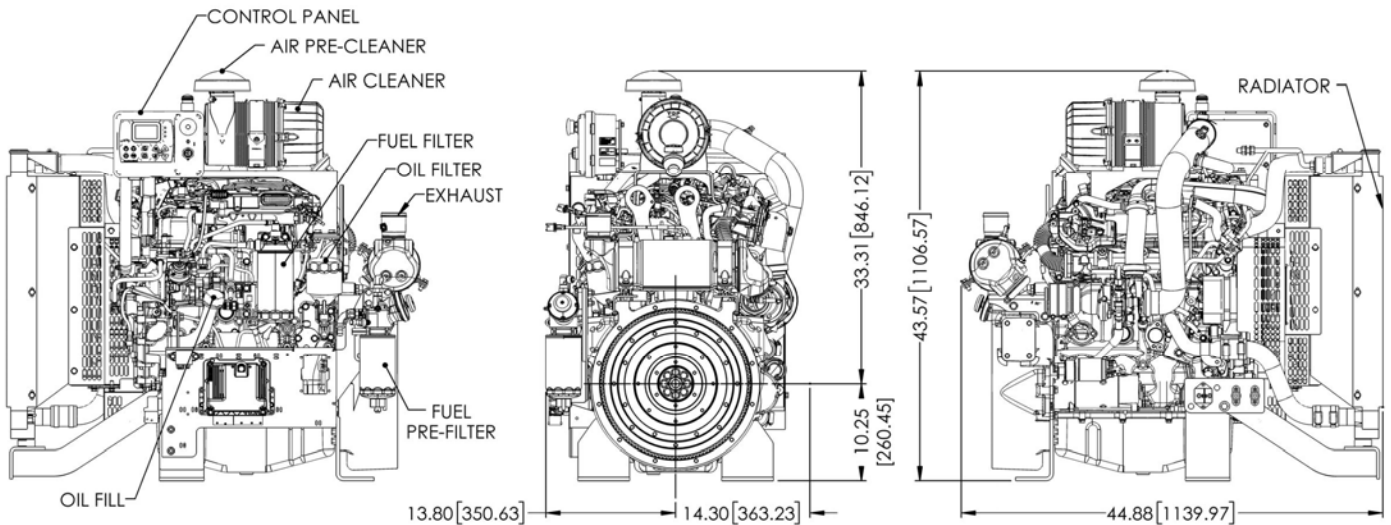

74hp (55kW)

Stauffer Diesel Inc / Stadco  Industrial Engine Distributor since 1956