

Designed for the demands of any application

The NEF 45 engine stands out for performance and reliability, with a lean 4.5-liter, four-cylinder engine design with single-stage turbocharging and no EGR. Thanks to FPT Industrial's pioneering EGR-free combustion and exclusive, patented HI-eSCR 2 after-treatment technology, the NEF Series represents the productivity benchmark in mid-range applications and offers further enhancements in performance and efficiency with newly designed Stage V engines.

SPECIFICATIONS

Type	Diesel 4 Stroke
Configuration	Inline 4 Cylinder
Air Handling	Turbocharged Aftercooled
Bore X stroke	104 x 132 mm
Displacement	4.5 L
Compression Ratio	17:1
Valves per Cylinder	4
Rotation	CCW
Fuel System	Electronic Common Rail

AFTER TREATMENT SYSTEM

Tier 4F only	DOC + SCR
Tier 4F / Stage V	DOC + SCRof

PERFORMANCE RATINGS

103 kW (138 HP) @ 2200 RPM	637 Nm @ 1500 RPM
125 kW (168 HP) @ 2200 RPM	712 Nm @ 1500 RPM
147 kW (200 HP) @ 2100 RPM	744 Nm @ 1400 RPM*

*Bare Engine (Tier 4F / Stage V)

STANDARD CONFIGURATION**

Emissions Level	Tier 4F / Stage V
Flywheel Housing	SAE 3
Flywheel Housing	11.5"
Oil Sump	Front
Voltage	12V / 24V
Alternator	70A 24V
Starter	3.2 kW / 5.5 kW
Powerpack Dimensions	1409 x 1035 x 1698 mm
Powerpack Weight	725 kg

**Flexible configurations are available.

KEY FEATURES:

- High performance and competitive fuel efficiency
- Hi-eSCR2 technology EGR-free for lower running costs
- DPF-free ATS Tier 4 Final only
- Best-in-class 600-hour service interval maximizes uptime
- Flexible configurations to meet your needs:
 - 4.5-liter displacement
 - Power up to 147 kW (200 HP)
 - Torque up to 744 Nm (549 lb/ft)
- Dual-certified, Tier 4F / Stage V (avoid layout changes)

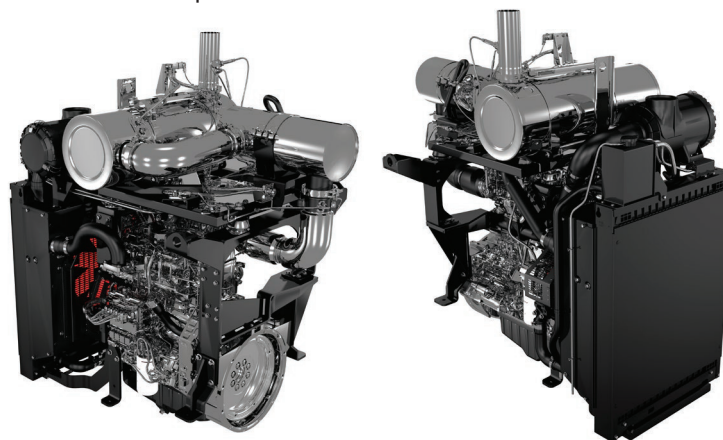

ENGINE PERFORMANCE DATA

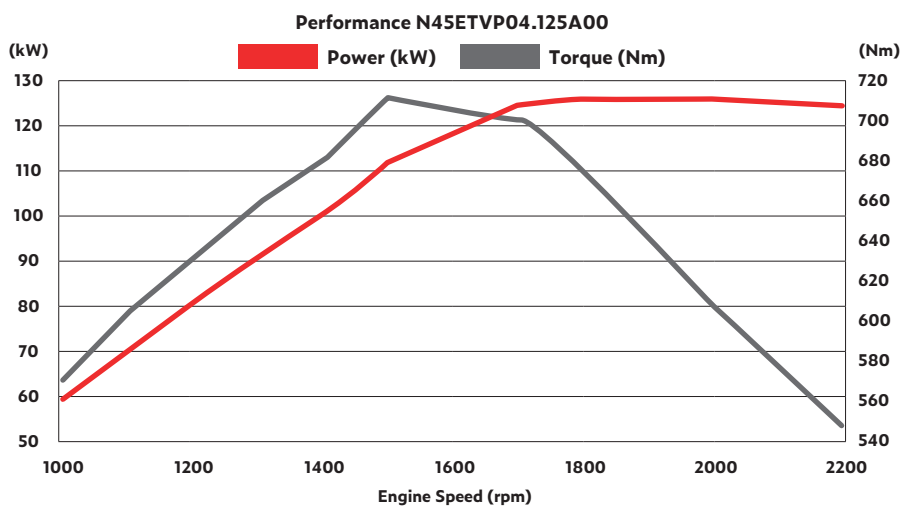

OFF-ROAD INDUSTRIAL

NEF 45

103 - 147 kW (138 - 200 HP)



NEF 45 - Available in Tier 4 Final only and Stage V / T4 Final dual certified

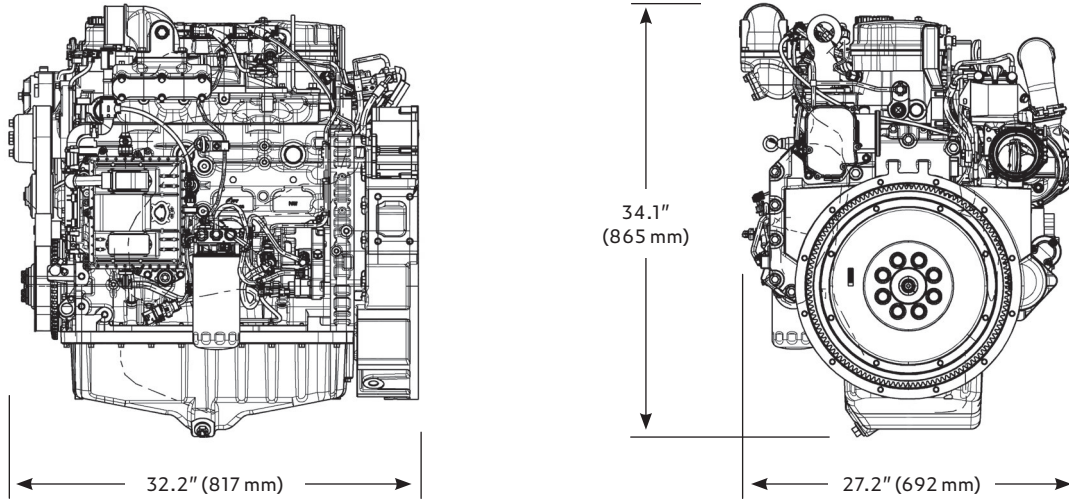

NEF 45 POWERPACK - Available in Stage V / Tier 4 Final dual certified

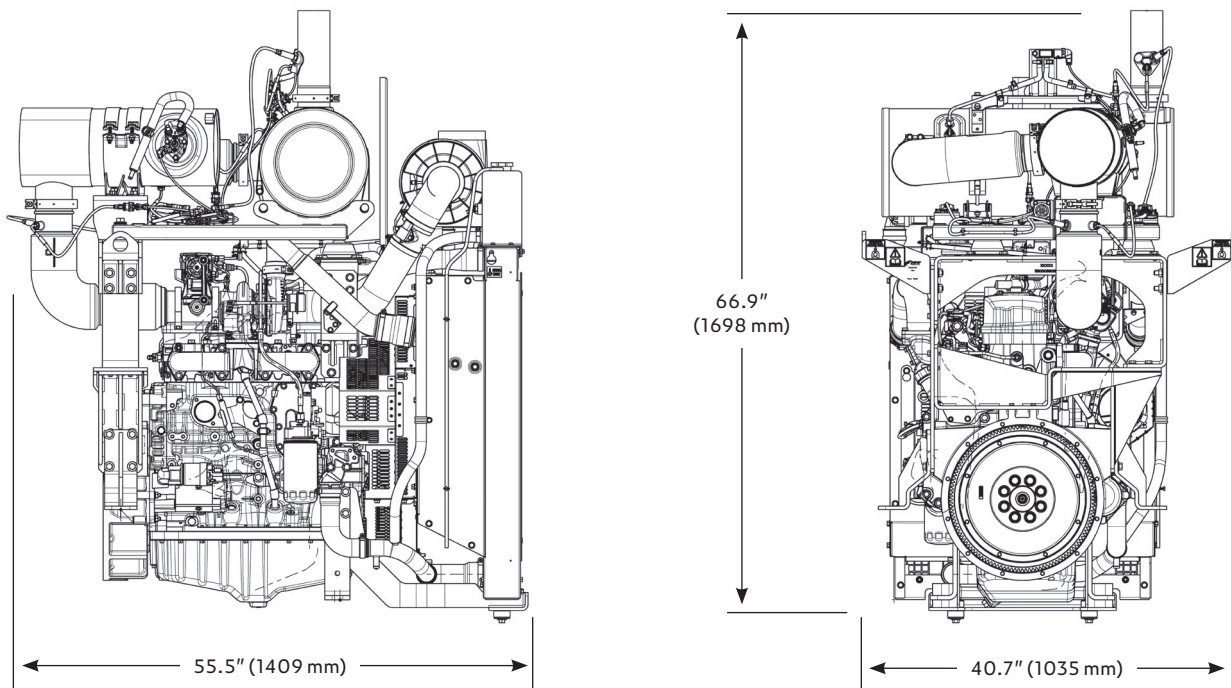

DISTRIBUTOR

Stauffer Diesel Inc.
34 Stauffer Lane, Ephrata, PA 17522
www.staufferdiesel.com
Contact: Michael Balsler at 800.377.2120