

## High performance in a compact layout

The F34 engine is a compact, flexible solution for light and mid-range applications, delivering high performance with low operating costs. These FPT Industrial engines offer top performance in a very compact layout that facilitates product development. The optimized design of turbo-compressors and pistons provides power and extraordinary torque density for any application.

### SPECIFICATIONS

Type	Diesel 4 Stroke
Configuration	Inline 4 Cylinder
Air Handling	Turbocharged
Bore X stroke	99 x 110 mm
Displacement	3.4 L
Compression Ratio	17:1
Valves per Cylinder	42
Rotation	CCW
Fuel System	Electronic Common Rail

### AFTER TREATMENT SYSTEM

55 kW	DOC + PM CAT
75 kW	DOC + SCR
90 kW	DOC + SCR

### PERFORMANCE RATINGS

55 kW (74 HP) @ 2200 RPM	318 Nm @ 1400 RPM
75 kW (101 HP) @ 2200 RPM	430 Nm @ 1400 RPM
90 kW (121 HP) @ 2200 RPM	490 Nm @ 1400 RPM

### STANDARD CONFIGURATION

Emissions Level	Tier 4F
Flywheel Housing	SAE 3
Flywheel Housing	11.5"
Oil Sump	Center
Voltage	12V
Alternator	12V - 120 A
Starter	12V - 4.5 kW
Powerpack Dimensions	1186 x 726 x 1090 mm (55kW rating)
Powerpack Weight	470 kg

### KEY FEATURES:

- High performance in compact layout
- Complete solution with mounted ATS for layout optimization
- ATS without DPF in Tier 4F minimizes downtime and operating costs
- Best-in-class 600-hour service interval minimizes downtime
- 3.4-liter displacement
- Power up to 90 kW (121 HP)
- Torque up to 490 Nm (361 lb/ft)

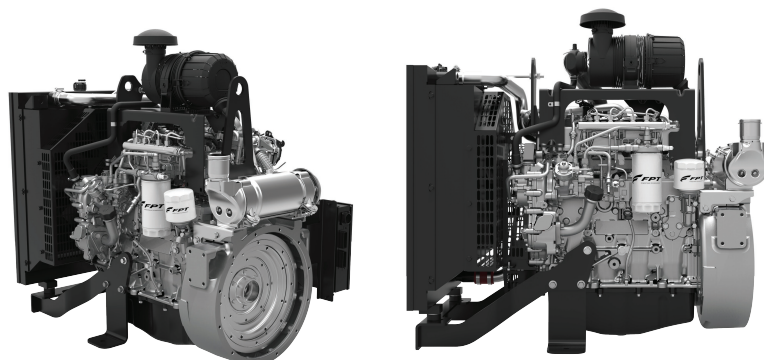

### ENGINE PERFORMANCE DATA

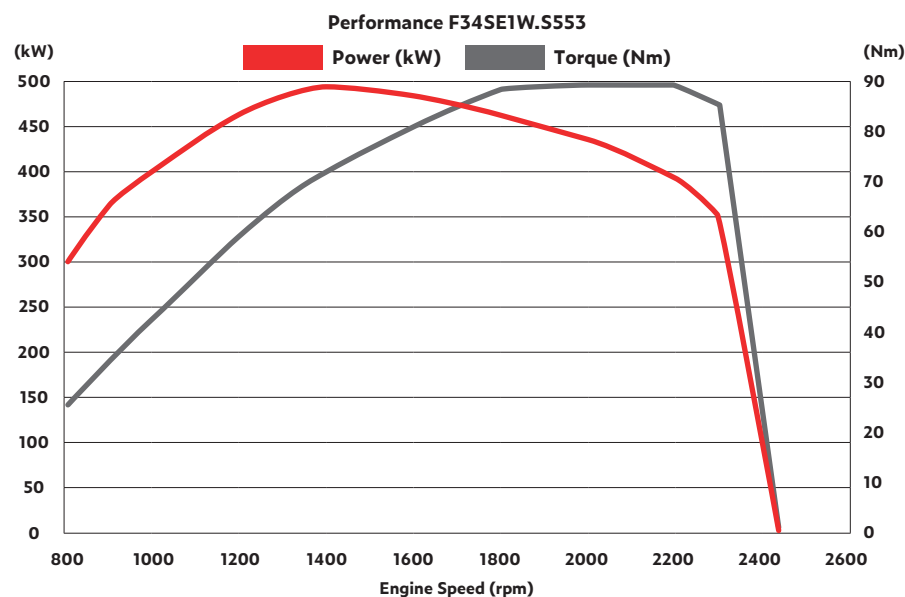

## F34

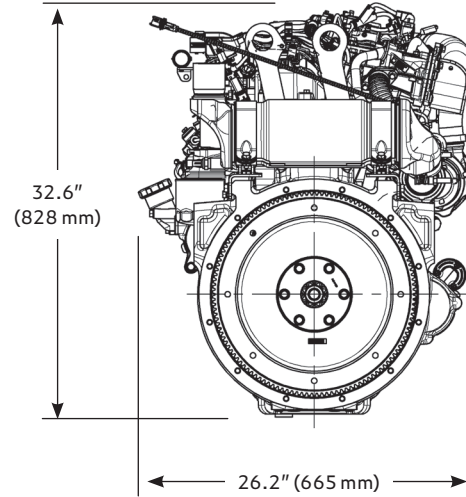
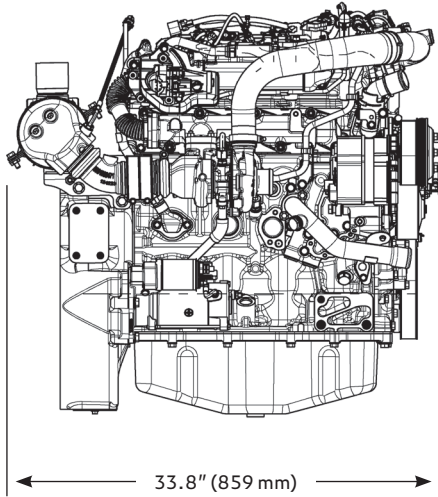

## F34 POWERPACK

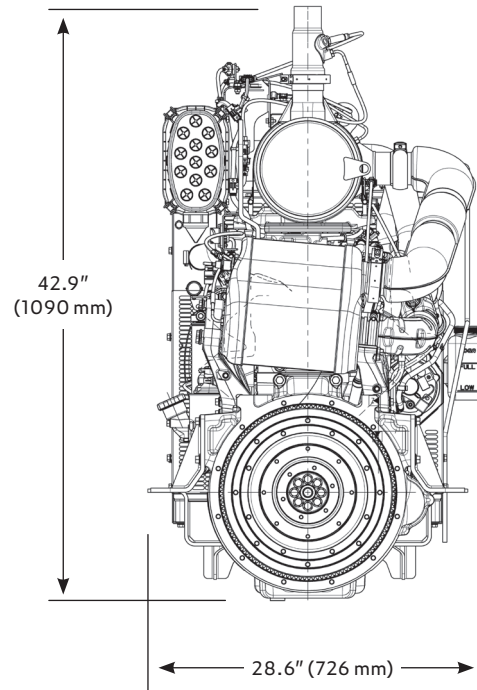
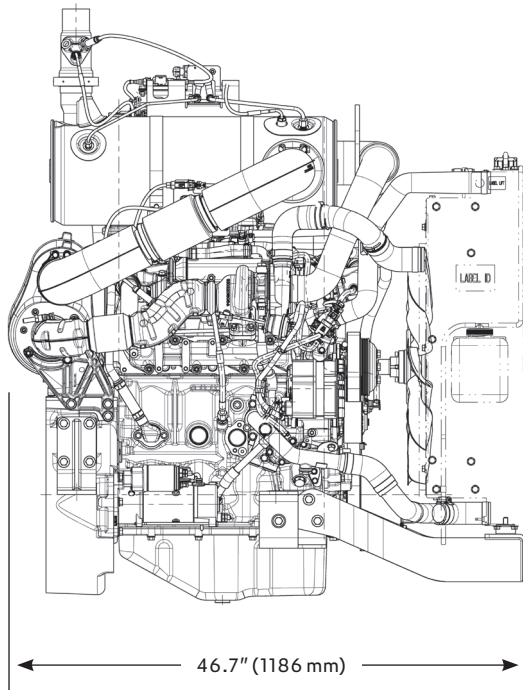

**DISTRIBUTOR**

**Stauffer Diesel Inc.**  
34 Stauffer Lane, Ephrata, PA 17522  
[www.staufferdiesel.com](http://www.staufferdiesel.com)  
**Contact: Michael Balsler at 800.377.2120**