

OFF-ROAD INDUSTRIAL CURSOR 16

480 kW (644 HP)



Optimum solutions for high-demand applications

The Cursor 16 delivers 18 liter performance in a 13 liter package, with leading power-to-weight ratio (0.5 hp/kg) and an output of 480kW. The Cursor 16 is EGR-free, DPF-Free and features a "Fit-and-Forget" after-treatment system that does not require maintenance or regeneration, thanks to FPT's exclusive HI-eSCR Tier 4 Final technology. The Cursor 16 represents the most efficient after-treatment solution on the market, ensuring low fuel consumption, minimum operating costs, and maximum uptime.

SPECIFICATIONS

Type	Diesel 4 Stroke
Configuration	Inline 6 Cylinder
Air Handling	Turbocharged Aftercooled
Bore X stroke	141 x 170 mm
Displacement	15.9 L
Compression Ratio	16.5:1
Valves per Cylinder	4
Rotation	CCW
Fuel System	Electronic Common Rail

AFTER TREATMENT SYSTEM

Tier 4F	DOC + SCR
---------	-----------

PERFORMANCE RATINGS

480 kW (644 HP) @ 2100 RPM	2751 Nm @ 1500 RPM
----------------------------	--------------------

STANDARD CONFIGURATION

Emissions Level	Tier 4F
Flywheel Housing	SAE 1
Flywheel Housing	17"
Oil Sump	Center
Voltage	12V / 24V
Alternator	90A - 24V
Starter	7.5 kW - 24V
Dimensions	1378 x 954 x 1284 mm
Weight	1450 kg

KEY FEATURES:

- Optimum solutions for high-demand applications
- Hi-eSCR technology (no DPF) - EGR-free for lower running costs
- Superior performance and lean design
- Best-in-class 600-hour service interval minimizes downtime
- Flexible configurations to meet your needs:
 - 15.9-liter displacement
 - Power up to 480 kW (644 HP)
 - Torque up to 2751 Nm (2029 lb/ft)

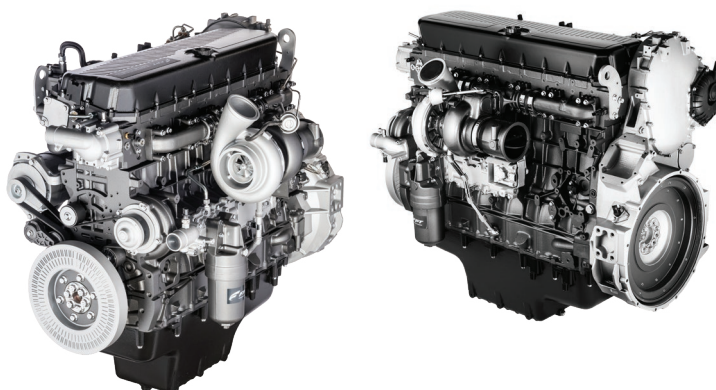

ENGINE PERFORMANCE DATA

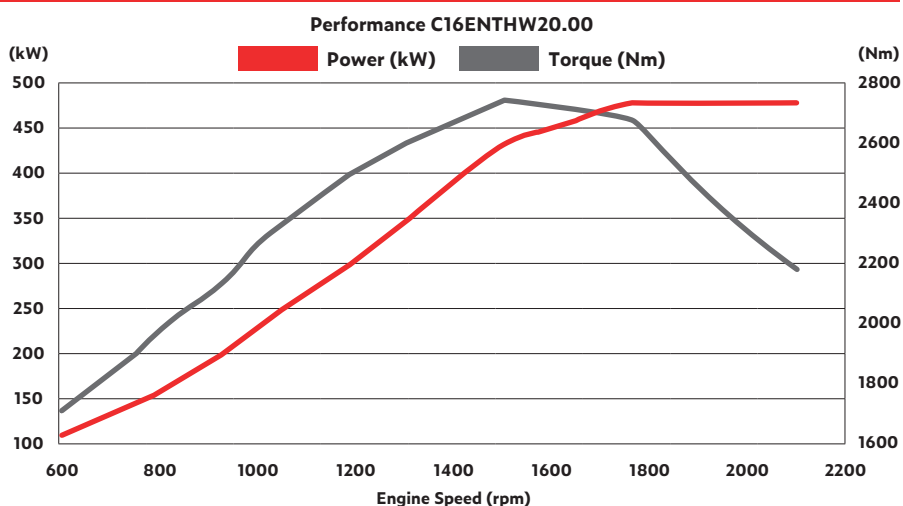

OFF-ROAD INDUSTRIAL
CURSOR 16
480 kW (644 HP)



CURSOR 16

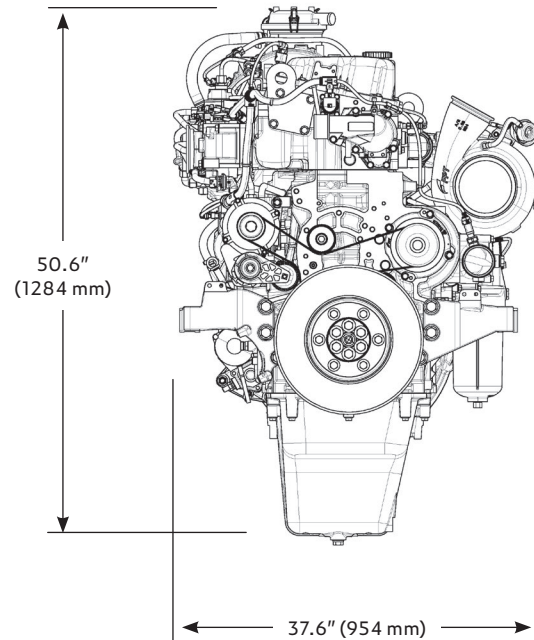
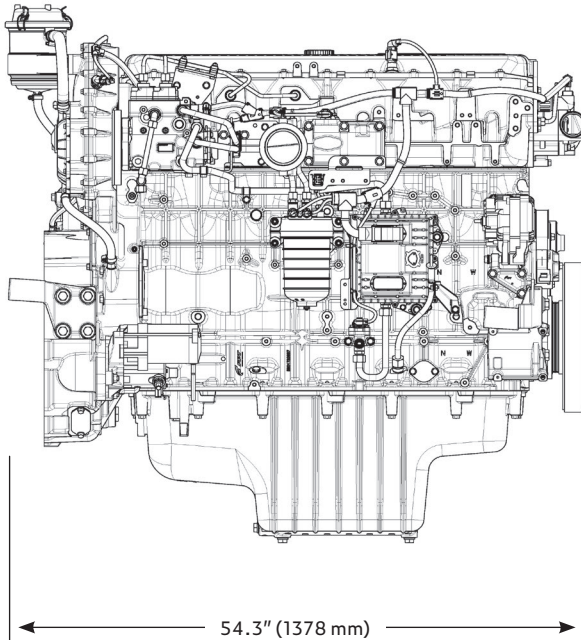

DISTRIBUTOR

Stauffer Diesel Inc.
34 Stauffer Lane, Ephrata, PA 17522
www.staufferdiesel.com
Contact: Michael Balsler at 800.377.2120