

OFF-ROAD INDUSTRIAL CURSOR 13

346 - 407 kW (464 - 546 HP)



Rugged and reliability in all working conditions

The high-powered Cursor 13 features a six-cylinder, 12.9-liter design to provide reliable performance in heavy-duty applications. All power units powered by FPT Industrial are designed for highly efficient power output and quick load response, high power density and low running costs. The Cursor 13 is compliant with Stage V and Tier 4 Final regulations, using the patented HI-eSCR 2 system, the most efficient SCR system available on the market without EGR.

SPECIFICATIONS

Type	Diesel 4 Stroke
Configuration	Inline 6 Cylinder
Air Handling	Turbocharged Aftercooled
Bore X stroke	135 x 150 mm
Displacement	12.9 L
Compression Ratio	16.5:1
Valves per Cylinder	4
Rotation	CCW
Fuel System	Electronic Common Rail

AFTER TREATMENT SYSTEM

Tier 4F only	DOC + SCR
Tier 4F / Stage V	DOC + SCRoF

PERFORMANCE RATINGS

346 kW (464 HP) @ 2100 RPM	2012 Nm @ 1400 RPM
384 kW (515 HP) @ 2100 RPM	2300 Nm @ 1400 RPM
407 kW (546 HP) @ 2100 RPM	2400 Nm @ 1400 RPM

STANDARD CONFIGURATION*

Emissions Level	Tier 4F / Stage V
Flywheel Housing	SAE 1
Flywheel Housing	14"
Oil Sump	Front
Voltage	24V
Alternator	24V - 90A
Starter	24V - 7.8 kW
Powerpack Dimensions	2318 x 1223 x 1454 mm
Powerpack Weight	1399 kg + ATS

*Flexible configurations are available.

KEY FEATURES:

- Optimum solutions for high-demand applications
- Hi-eSCR2 technology - EGR-free for lower running costs
- Superior performance and lean design
- Best-in-class 600-hour service interval minimizes downtime
- Flexible configurations to meet your needs:
 - 12.9-liter displacement
 - Power up to 407 kW (546 HP)
 - Torque up to 2381 Nm (1756 lb/ft)
- US Tier 4 Final and EU Stage V dual certified

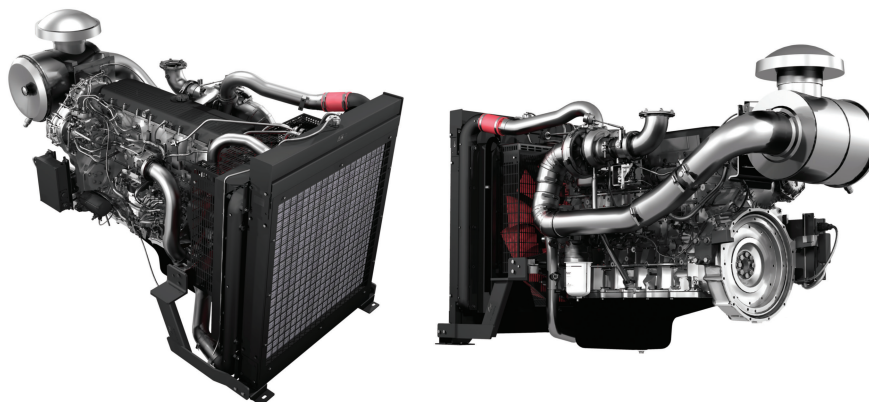

ENGINE PERFORMANCE DATA

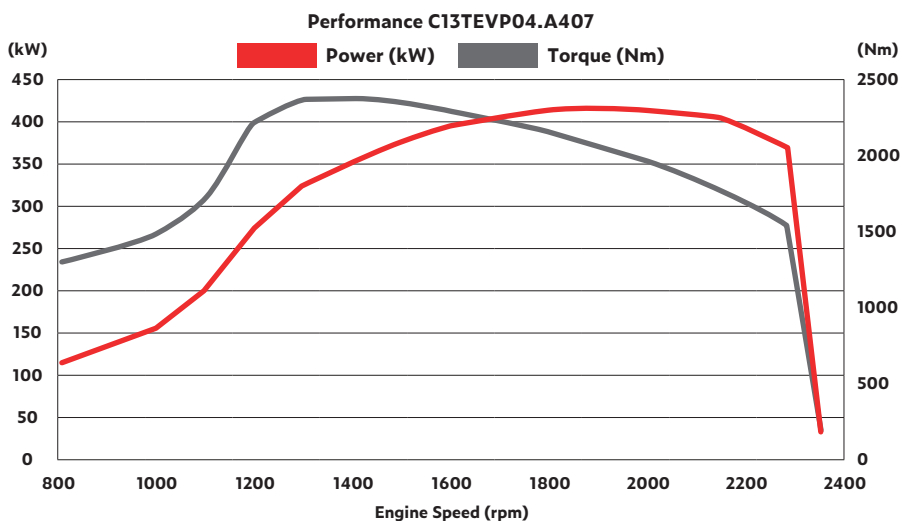

OFF-ROAD INDUSTRIAL
CURSOR 13
346 - 407 kW (464 - 546 HP)



CURSOR 13 - Available in Tier 4 Final only and Stage V / T4 Final dual certified

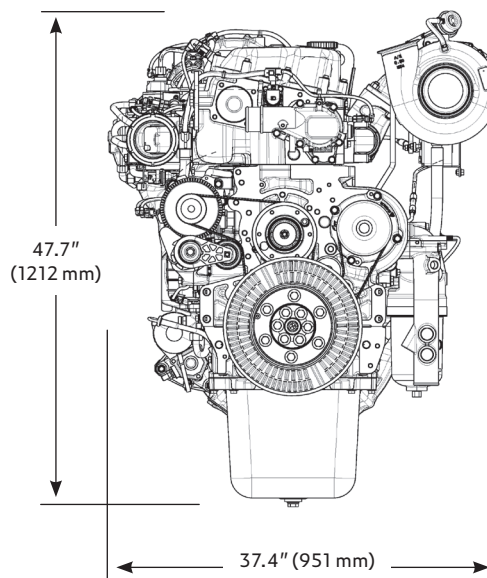
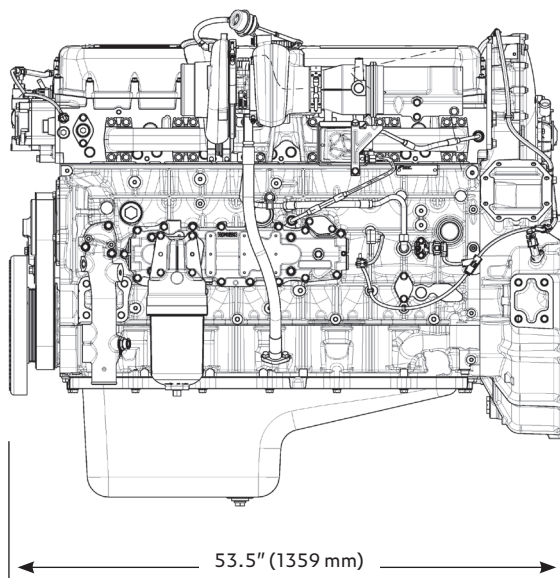

CURSOR 13 POWERPACK - Available in Stage V / Tier 4 Final dual certified

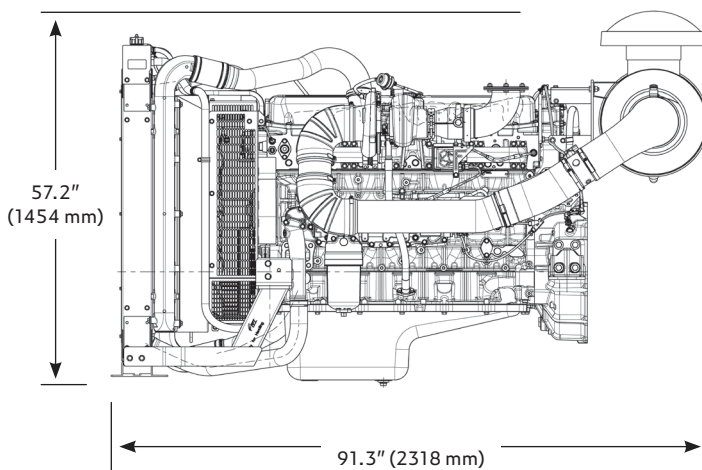

ATS Power Pack - Smart Installation Package

The ATS Pack includes all key after-treatment components in a single package: main catalysts and their relative sensors are included in a compact and pre-assembled set that requires no dedicated design or installation of ATS components. The pre-packed ATS solution has a pre-validated design in order to make the final validation process seamless, including a single electrical cable for fast, reliable and quick connection to any engine.

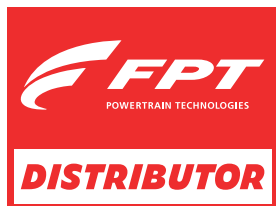

Stauffer Diesel Inc.
34 Stauffer Lane, Ephrata, PA 17522
www.staufferdiesel.com
Contact: Michael Balsler at 800.377.2120