



**Turbo**

# AIR DIESEL

The World's First Engine



and still the Best!

EPA Tier 3 Certified.  
The Clean Air Diesel.

## TCD914 L6 SERIES 164 Hp

<b>Deutz Model</b>		<b>TCD914 L6</b>
<b>Engine Type</b>		
<b>No. of Cylinders</b>		6
<b>Bore/Stroke</b>	<b>inches(mm)</b>	4.02 / 5.20 (102/132)
<b>Displacement</b>	<b>Cubic In.(liter)</b>	395 (6.5)
<b>Aspiration</b>		Turbo/Aftercooled
<b>Power Ratings</b>		
<b>* Intermittent Duty HP Gross (Net)</b>	<b>1500 RPM</b>	125.0 (122.0)
	<b>1800 RPM</b>	146.0 (141.0)
	<b>2000 RPM</b>	159.0 (153.0)
	<b>2300 RPM</b>	174.0 (164.0)
<b>* Continuous Duty HP Gross (Net)</b>	<b>1500 RPM</b>	110.0 (107.0)
	<b>1800 RPM</b>	139.0 (135.0)
	<b>2000 RPM</b>	151.0 (145.0)
	<b>2300 RPM</b>	168.0 (158.0)
<b>Max. torque</b>	<b>ft/lbs. (Nm)</b>	461 (625)
<b>RPM @ max torque</b>		1600
<b>Fuel Consumption</b>	<b>lbs/hphr (g/kwh)</b>	.347 (210)
<b>Weight includes cooling system</b>		1122 lbs.
<b>* Gen-drive Standby Duty 1800 RPM</b>	<b>HP Gross (Net)</b>	174.0 (169.0)
	<b>kW Gross (Net)</b>	129.9 (126.2)
<small>* Net Ratings include parasitic load of cooling fan, air cleaner, muffler, alternator idling</small>		

The values given in this data sheet are for information purposes only and are not guaranteed.

- **Tier 3 Compliant** - Mechanical governor and injection - No digital electronics.
- **Reliability** - Dependable power no matter how harsh the environment. Direct air cooling, with no coolant to freeze or boil, reduces the likelihood of engine failure even in extreme temperatures.
- **Durability** - Advanced manufacturing processes, years of research and development and high standards for quality control assure your engine will keep running tomorrow.
- **Fuel Economy** - Advanced fuel system design and reduced power requirements for cooling make Deutz Air cooled diesels a leader in fuel economy.
- **Easy Maintenance** - No coolant, radiator and water pumps to maintain. Individual cylinders and parts interchangeability within engine series, reduce inventory and service costs.



*Air Diesel*

**THE LEGEND  
LIVES**

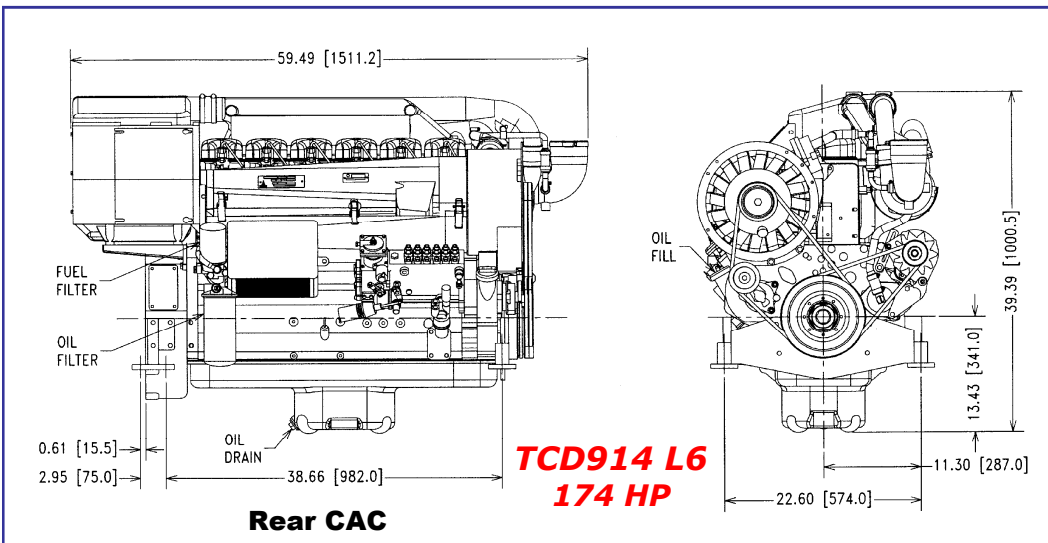

**BASIC EQUIPMENT**

- Adapter Housing
- Flywheel
- Rigid Mounting Feet
- O.B. Air Cleaner
- Spin-on Oil & Fuel Filters
- Fuel pump
- 12V. Starter
- 12V. Alternator
- V-belt break Switch
- Wiring Harness
- Shut down Solenoid

*EPA Tier 3 Certified. The Clean Air Diesel.*

***NEW! Deutz Engines now covered by 3-Year Limited Warranty.***

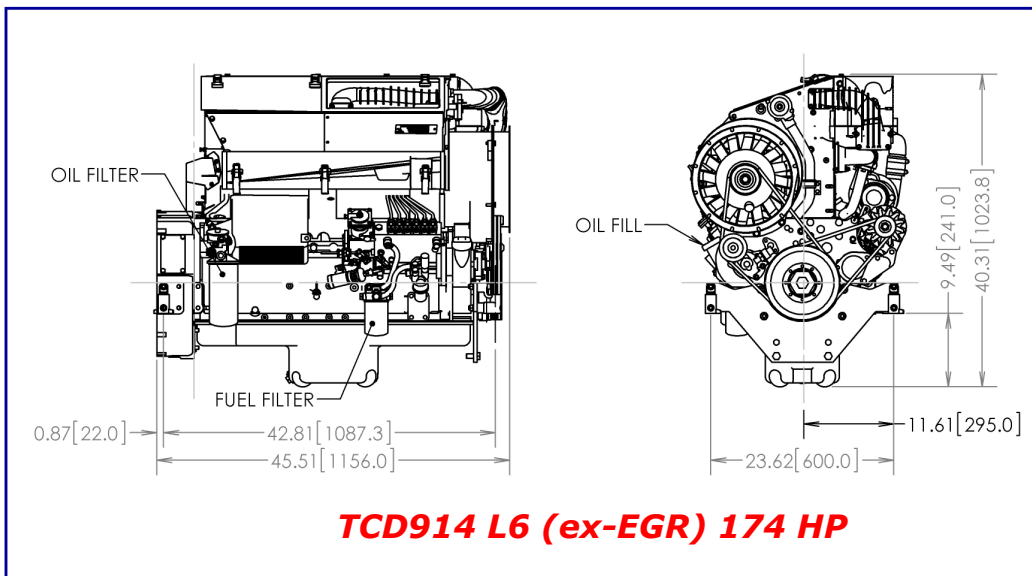

**OPTIONAL EQUIPMENT**

- Air Cleaners
- Pre-cleaners
- Engine Flex Mounts
- Instrument Panels
- Starting Aids
- PTO Clutches
- PTO Stub shafts